

# "Charging Lithium-Ion Batteries: Not All Charging Systems Are Created Equal"

By Scott Dearborn  
Principal Applications Engineer  
Microchip Technology Inc.  
2355 West Chandler Blvd  
Chandler, AZ 85224  
[www.microchip.com](http://www.microchip.com)

## INTRODUCTION

Powering today's portable world poses many challenges for system designers. The use of batteries as a prime power source is on the rise. As a result, a burden has been placed on the system designer to create sophisticated systems utilizing the battery's full potential.

Each application is unique, but one common theme rings through: *maximize battery capacity usage*. This theme directly relates to how energy is properly restored to rechargeable batteries. No single method is ideal for all applications. An understanding of the charging characteristics of the battery and the application's requirements is essential in order to design an appropriate and reliable battery charging system. Each method has its associated advantages and disadvantages. It is the particular application with its individual requirements that determines which method will be the best to use.

Far too often, the charging system is given low priority, especially in cost-sensitive applications. The quality of the charging system, however, plays a key role in the life and reliability of the battery. In this article, the fundamentals of charging Lithium-Ion (Li-Ion) batteries are explored. In particular, linear charging solutions and a microcontroller-based, switch-mode solution shall be explored. Microchip's MCP73843 and MCP73861 linear charge management controllers and PIC16F684 microcontroller along with a MCP1630 pulse width modulator (PWM), shall be used as examples.

## LI-ION CHARGING

The rate of charge or discharge is often expressed in relation to the capacity of the battery. This rate is known as the C-Rate. The C-Rate equates to a charge or discharge current and is defined as:

$$I = M \times C_n$$

where:

I = charge or discharge current, A

M = multiple or fraction of C

C = numerical value of rated capacity, Ah

n = time in hours at which C is declared.

A battery discharging at a C-rate of 1 will deliver its nominal rated capacity in one hour. For example, if the rated capacity is 1000mAh, a discharge rate of 1C corresponds to a discharge current of 1000mA. A rate of C/10 corresponds to a discharge current of 100mA.

Typically, manufacturers specify the capacity of a battery at a 5 hour rate,  $n = 5$ . For example, the above-mentioned battery would provide 5 hours of operating time when discharged at a constant current of 200mA. In theory, the battery would provide 1 hour of operating time when discharged at a constant current of 1000mA. In practice, however, the operating time will be less than 1 hour due to inefficiencies in the discharge cycle.

So how is energy properly restored to a Li-Ion battery? The preferred charge algorithm for Li-Ion battery chemistries is a constant, or controlled, current -- constant voltage algorithm that can be broken up into four stages: trickle charge, constant current charge, constant voltage charge, and charge termination. Refer to Figure 1.

Stage 1: Trickle Charge -- Trickle charge is employed to restore charge to deeply depleted cells. When the cell voltage is below approximately 3V, the cell is charged with a constant current of 0.1C maximum.

Stage 2: Constant Current Charge -- After the cell voltage has risen above the trickle charge threshold, the charge current is raised to perform constant current charging. The constant current charge should be in the 0.2C to 1.0C range. The constant current does not need to be precise and semi-constant current is allowed. Often, in linear chargers, the current is ramped-up as the cell voltage rises in order to minimize heat dissipation in the pass transistor.

Charging at constant current rates above 1C does not reduce the overall charge cycle time and should be avoided. When charging at higher currents, the cell voltage rises more rapidly due to over-voltage in the electrode reactions and the increased voltage across the internal resistance of the cell. The constant current stage becomes shorter, but the overall charge cycle time is not reduced because the percentage of time in the constant voltage stage increases proportionately.

Stage 3: Constant Voltage -- Constant current charge ends and the constant voltage stage is invoked when the cell voltage reaches 4.2V. In order to maximize performance, the voltage regulation tolerance should be better than +1%.

Stage 4: Charge Termination -- Unlike nickel-based batteries, it is not recommended to continue to trickle charge Li-Ion batteries. Continuing to trickle charge can cause plating of metallic lithium, a condition that makes the battery unstable. The result can be sudden, automatic, and rapid disassembly.

Charging is typically terminated by one of two methods: minimum charge current or a timer (or a combination of the two). The minimum current approach monitors the charge current during the constant voltage stage and terminates the charge when the charge current diminishes in the range of 0.02C to 0.07C. The second method determines when the constant voltage stage is invoked. Charging continues for an additional two hours, and then the charge is terminated.

Charging in this manner replenishes a deeply depleted battery in roughly 2.5 to 3 hours.

Advanced chargers employ additional safety features. For example the charge is suspended if the cell temperature is outside a specified window, typically 0°C to 45°C.

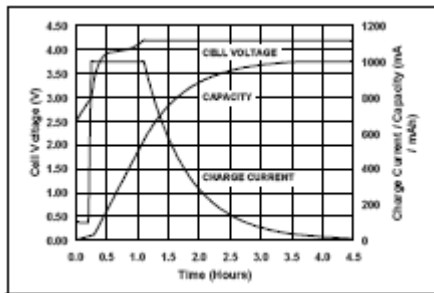

Figure 1: Li-Ion Charge Profile

## LI-ION CHARGING -- SYSTEM CONSIDERATIONS

A high-performance charging system is required to recharge any battery quickly and reliably. The following system parameters should be considered in order to ensure a reliable, cost-effective solution.

### Input Source

Many applications use very inexpensive wall cubes for the input supply. The output voltage is highly dependent on the ac input voltage and the load current being drawn from the wall cube.

In the US, the ac mains input voltage can vary from 90VRMS to 132VRMS for a standard wall outlet. Assuming a nominal input voltage of 120VRMS, the tolerance is +10%, -25%. The charger must provide proper regulation to the battery independent of its input voltage. The input voltage to the charger will scale in accordance to the AC mains voltage and the charge current:

$$V_O = \sqrt{2} \times V_{IN} \times a - I_O (R_{EQ} + R_{PTC}) - 2 \times V_{FD}$$

$R_{EQ}$  is the resistance of the secondary winding plus the reflected resistance of the primary winding ( $R_P / a^2$ ).

$R_{PTC}$  is the resistance of the PTC, and  $V_{FD}$  is the forward drop of the bridge rectifiers. In addition, transformer core loss will slightly reduce the output voltage.

Applications that charge from a car adapter can experience a similar problem. The output voltage of car adapter will have a typical range of 9V to 18V.

### Constant Current Charge Rate and Accuracy

The choice of topology for a given application may be determined by the desired constant current. Many high constant current, or multiple cell applications rely on a switch-mode charging solution for improved efficiency and less heat generation.

Linear solutions are desirable in low to moderate fast charge current applications for their superior size and cost considerations. However, a linear solution purposely dissipates excess power in the form of heat.

The tolerance on the constant current charge becomes extremely important to a linear system. If the regulation tolerance is loose, pass transistors and other components will need to be oversized adding size and cost. In addition, if the constant current charge is low, the complete charge cycle will be extended.

### **Output Voltage Regulation Accuracy**

The output voltage regulation accuracy is critical in order to obtain the desired goal: maximize battery capacity usage. A small decrease in output voltage accuracy results in a large decrease in capacity. However, the output voltage can not be set arbitrarily high because of safety and reliability concerns.

Figure 2 depicts the importance of output voltage regulation accuracy:

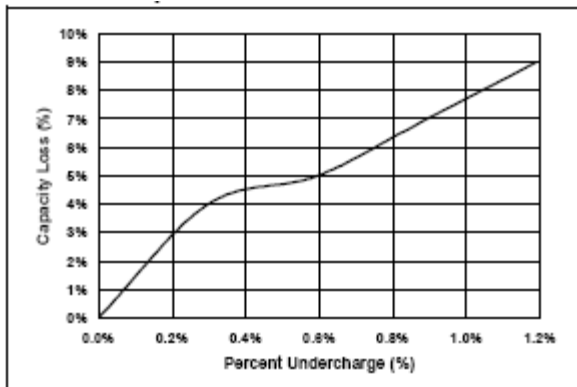

*Figure 2: Capacity Loss vs. Undercharge Voltage*

### **Charge Termination Method**

It can not be stressed enough that over charging is the Achilles' heel of Li-Ion cells. Accurate charge termination methods are essential for a safe, reliable, charging system.

### **Cell Temperature Monitoring**

The temperature range over which a Li-Ion battery should be charged is 0°C to 45°C, typically. Charging the battery at temperatures outside of this range may cause the battery to become hot. During a charge cycle, the pressure inside the battery increases causing the battery to swell. Temperature and pressure are directly related. As the temperature rises, the pressure can become excessive. This can lead to a mechanical breakdown inside the battery or venting. Charging the battery outside of this temperature range may also harm the performance of the battery or reduce the battery's life expectancy.

Generally, thermistors are included in Lithium-Ion battery packs in order to accurately measure the battery temperature. The charger measures the resistance value of the thermistor between the thermistor terminal and the negative terminal. Charging is inhibited when the resistance, and therefore the temperature, is outside the specified operating range.

## Battery Discharge Current or Reverse Leakage Current

In many applications, the charging system remains connected to the battery in the absence of input power. The charging system should minimize the current drain from the battery when input power is not present. The maximum current drain should be below a few microamperes and, typically, should be below one microampere.

## LI-ION CHARGING -- APPLICATION EXAMPLES

Taking the above system considerations into account, an appropriate charge management system can be developed.

### Linear Solutions

Linear charging solutions are generally employed when a well-regulated input source is available. Linear solutions, in these applications, offer advantages of ease of use, size, and cost.

Due to the low efficiency of a linear charging solution, the most important factor is the thermal design. The thermal design is a direct function of the input voltage, charge current and thermal impedance between the pass transistor and the ambient cooling air. The worst-case situation is when the device transitions from the trickle charge stage to the constant current stage. In this situation, the pass transistor has to dissipate the maximum power. A trade-off must be made between the charge current, size, cost and thermal requirements of the charging system.

Take, for example, an application required to charge a 1000mAh, single Li-Ion cell from a 5V +/- 5% input at a constant current charge rate of 0.5C or 1C. Figure 3 depicts Microchip's MCP73843 used to produce a low cost, stand-alone solution. With a few external components, the preferred charge algorithm is implemented.

The MCP73843 combines high accuracy constant current, constant voltage regulation with automatic charge termination.

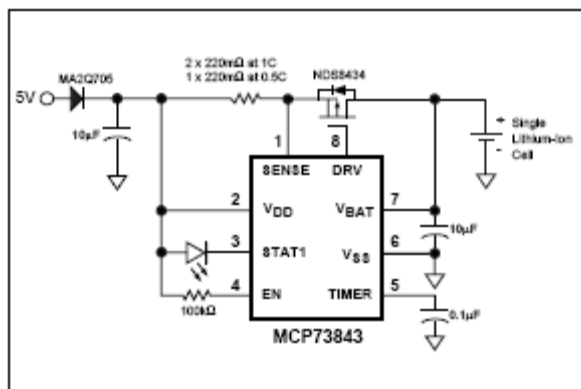

Figure 3: Typical Linear Solution

In an effort to further reduce size, cost, and complexity of linear solutions, many of the external components can be integrated into the charge management controller. Advanced packaging and reduced flexibility come along with higher integration. These packages require advanced equipment for manufacturing, and, in many instances, preclude rework. Typically, integration encompasses charge current sensing, the pass transistor, and reverse discharge protection. In addition, these charge management controllers typically employ some type of thermal regulation. Thermal regulation optimizes the charge cycle time while maintaining device reliability by limiting the charge current based on the device die temperature. Thermal regulation greatly reduces the thermal design effort.

Figure 4 depicts a fully integrated, linear solution utilizing Microchip's MCP73861. The MCP73861 incorporates all the features of the MCP73843 along with charge current sensing, the pass transistor, reverse discharge protection, and cell temperature monitoring.

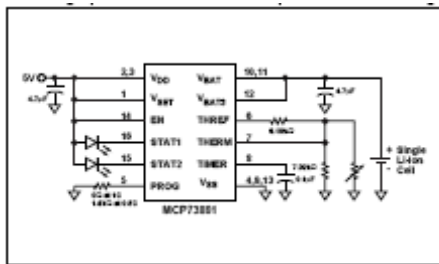

Figure 4: Typical, Fully Integrated, Linear Solution

### Charge Cycle Waveforms

Figure 5 depicts complete charge cycles utilizing the MCP73843 with constant current charge rates of 1C and 0.5C. Charging at a rate of 0.5C instead of 1C, it takes about 1 hour longer for the end of charge to be reached. The MCP73843 scales the charge termination current proportionately with the fast charge current. The result is an increase of 36% in charge time with the benefit of a 2% gain in capacity and reduced power dissipation. The change in termination current from 0.07C to 0.035C results in an increase in final capacity from ~98% to ~100%. The system designer has to make a trade-off between charge time, power dissipation, and available capacity.

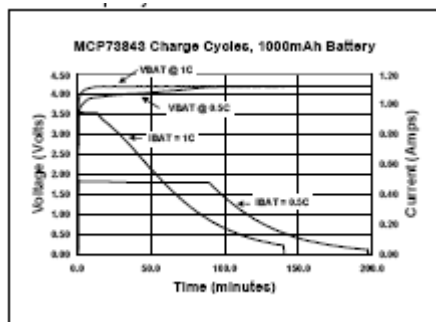

Figure 5: MCP73843 Charge Cycle Waveforms

## Switch-Mode Charging Solutions

Switch-mode charging solutions are generally employed in applications that have a wide ranging input or a high input to output voltage differential. In these applications, switch mode solutions have the advantage of improved efficiency. The disadvantage is system complexity, size, and cost.

Take, for example, an application required to charge a 2200mAh, single Li-Ion cell from a car adapter at a constant current charge rate of 0.5C or 1C. It would be extremely difficult to utilize a linear solution in this application due to the thermal issues involved. A linear solution employing thermal regulation could be utilized, but the charge cycle times at the reduced charge currents may be prohibitive.

The first step to designing a successful switch mode charging solution is to choose a topology: buck, boost, buck-boost, flyback, Single-Ended Primary Inductive Converter (SEPIC), or other. Knowing the input and output requirements, and experience, quickly narrows the choices down to two for this application: buck or SEPIC. A buck converter has the advantage of requiring a single inductor. Disadvantages of this topology include an additional diode required for reverse discharge protection, high-side gate drive and current sense, and pulsed input current (EMI concern).

The SEPIC topology has advantages that include lowside gate drive and current sense, continuous input current, and dc isolation from input to output. The main disadvantage of the SEPIC topology is the use of two inductors and an energy transfer capacitor.

Figure 6 depicts a schematic for a switch mode charger. Microchip's high speed Pulse Width Modulator (PWM), MCP1630, has been utilized in a pseudo smart battery charger application. The MCP1630 is a high-speed, microcontroller adaptable, pulse width modulator. When used in conjunction with a microcontroller, the MCP1630 will control the power system duty cycle to provide output voltage or current regulation. The microcontroller, PIC16F684, can be used to regulate output voltage or current, switching frequency, and maximum duty cycle. The MCP1630 generates duty cycle, and provides fast over current protection based off various external inputs. External signals include the input oscillator, the reference voltage, the feedback voltage, and the current sense. The output signal is a square-wave pulse. The power train used for the charger is SEPIC.

The microcontroller provides an enormous amount of design flexibility. In addition, the microcontroller can communicate with a battery monitor (Microchip's PS700) inside the battery pack to significantly reduce charge cycle times.

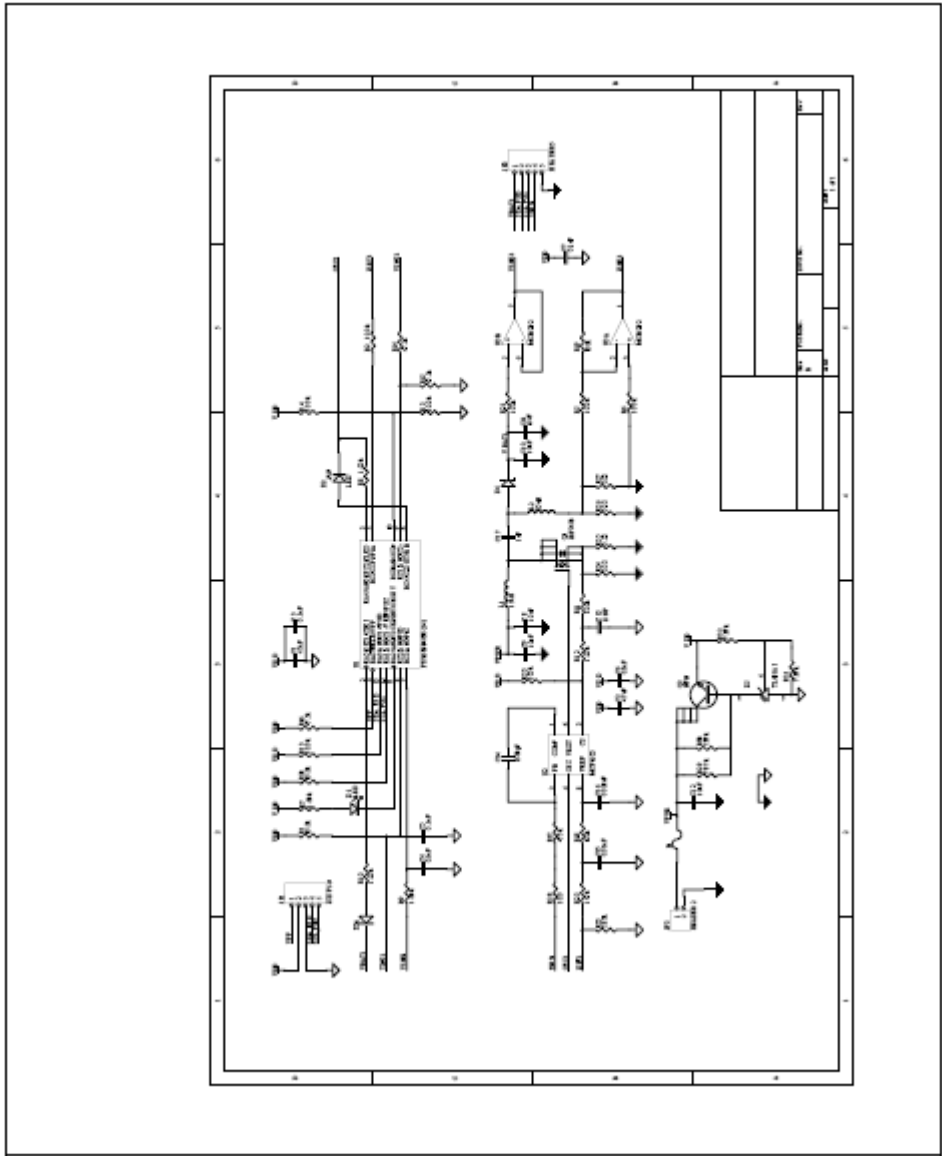

Figure 6: Switch-Mode SEPIC Charger

**Charge Cycle Waveforms**

Figure 7 depicts complete charge cycles utilizing the switch mode charging solution. By utilizing a battery monitor in the charging system, charge cycles can be significantly reduced. The battery monitor eliminates sensing the voltage produced across the packs protection circuitry and contact resistance by the charging current.



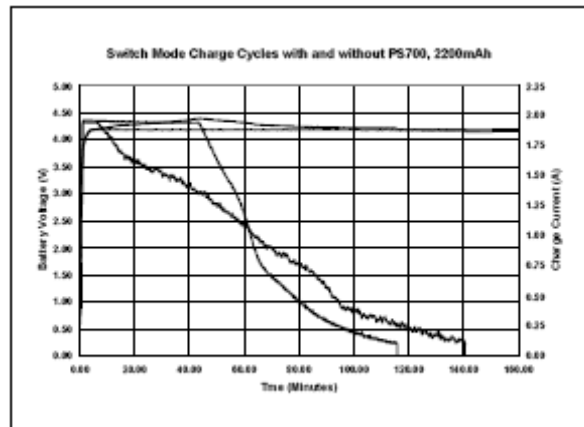

Figure 7

## CONCLUSION

Properly restoring energy using the latest battery technology for today's portable products requires careful consideration. An understanding of the charging characteristics of the battery and the application's requirements is essential in order to design an appropriate and reliable battery charging system.

Linear and switch mode charging solutions for Li-Ion batteries were presented. The guidelines and considerations presented herein should be taken into account when developing any battery charging system.

####

*Note: The Microchip name and logo, and PIC are registered trademarks of Microchip Technology Inc. in the USA and other countries. All other trademarks mentioned herein are property of their respective companies.*

## References

1. David Linden, Thomas B. Reddy, *Handbook of Batteries, Third Edition* (New York: McGraw-Hill, Inc., 2002).
2. [http://sanyo.com/batteries/lithium\\_ion.cfm](http://sanyo.com/batteries/lithium_ion.cfm)
3. MCP73843 Data Sheet, DS21823A.
4. MCP73861 Data Sheet, DS21893B.
5. MCP1630 Data Sheet, DS21896A.
6. PIC16F684 Data Sheet, DS41202C.
7. PS700 Data Sheet, DS21760F.